

NIDO

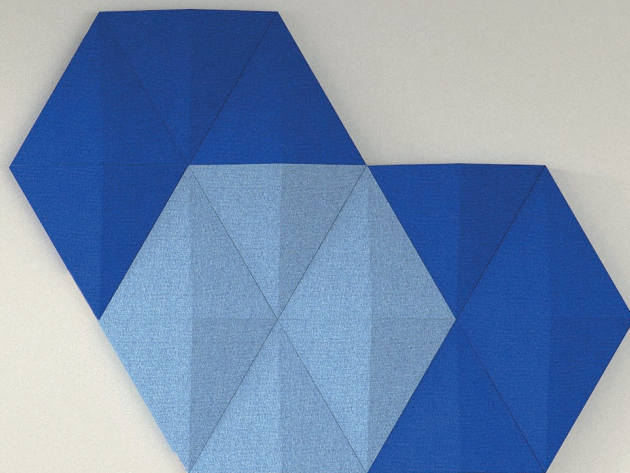

DROMEAS
OFFICE FURNITURE

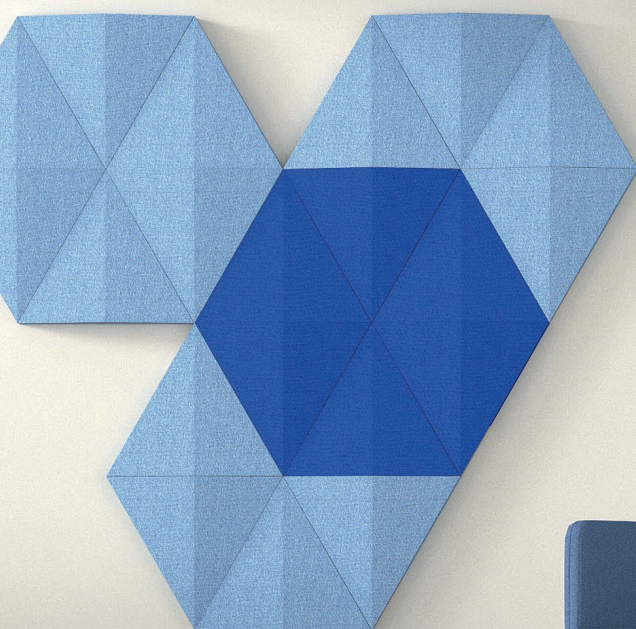



Διαστάσεις σε cm / Dimensions in cm

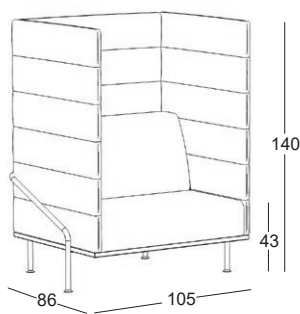
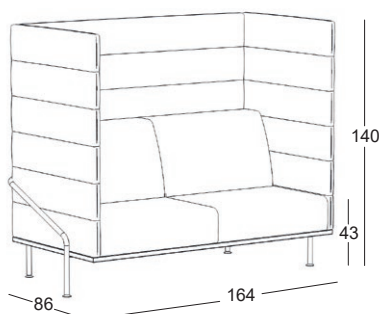

ΣΗΜΕΙΩΣΗ: Σύμφωνα με την τακτική της συνεχούς ανάπτυξης και βελτίωσης των προϊόντων μας, οι προδιαγραφές (σχεδιασμός, διαστάσεις, φινιρίσματα) μπορούν να αλλάξουν χωρίς προειδοποίηση.

NOTE: Due to our policy of continuous product development and improvement we reserve the right to change the specifications (design, dimensions, finishes) without prior notice.

GR. Καναπές-πολυθρόνα με ψηλά πλαίσια και πλάτη, προστατεύει τους χρήστες τόσο οπτικά όσο και ακουστικά από το περιβάλλον χάρη στις ηχοαπορροφητικές του ιδιότητες.

EN. Armchair with high side and back protects users from the environment both visually and acoustically thanks to its sound absorbing properties.



ΠΙΣΤΟΠΟΙΗΤΙΚΑ - CERTIFICATES



ΒΡΑΒΕΙΑ - AWARDS

ΕΡΓΟΣΤΑΣΙΟ: ΒΙ.ΠΕ. ΣΕΡΡΩΝ, Τ.Κ. 62 121, ΣΕΡΡΕΣ | Τ. 23210 99220 | F. 23210 99270 | 801 11 96000

PLANT: Industrial Area of Serres, 62 121, Serres, Greece | Τ. +30 23210 99220 | F. +30 23210 99270 |

www.dromeas.gr | e-mail: dromeas@dromeas.gr

ΑΘΗΝΑ: Λεωφ. Κηφισίας 324Α, Χαλάνδρι | Τ. 210 6835250

ΘΕΣΣΑΛΟΝΙΚΗ: Κ. Καραμανλή 112 | Τ. 2310 311601

DROMEAS BG - BXB: 1618 Sofia, blvd.Bulgaria 110 ground floor | Τ.+359 2 489 97 20 |

F. +359 2 489 97 21 | www.dromeas.bg | e-mail: office@dromeas.bg

DROMEAS BRUSSELS - BXB: Schaarbeeklei 605, 1800 Vilvoorde, Brussels - Belgium |

T. +32 -2-7510825 | e-mail: info@dromeas.be



DROMEAS
OFFICE FURNITURE